



## StyleWriter II

---





Basics

StyleWriter II





## Test Page

Turn on the printer and hold down the online key for at least 6 seconds or until the test page prints.

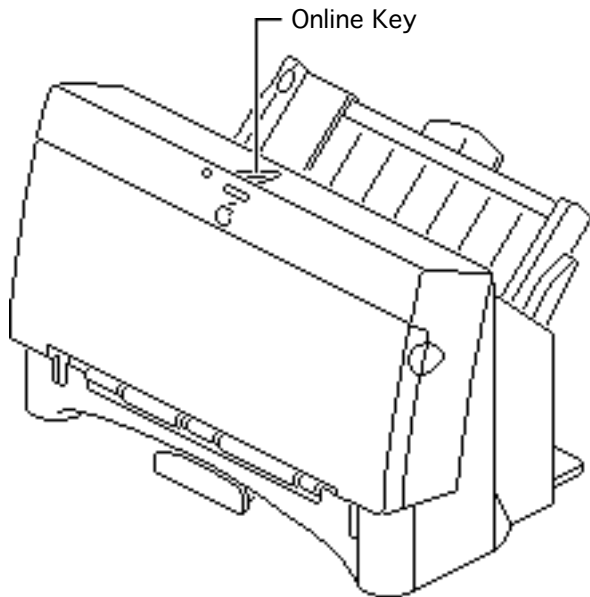

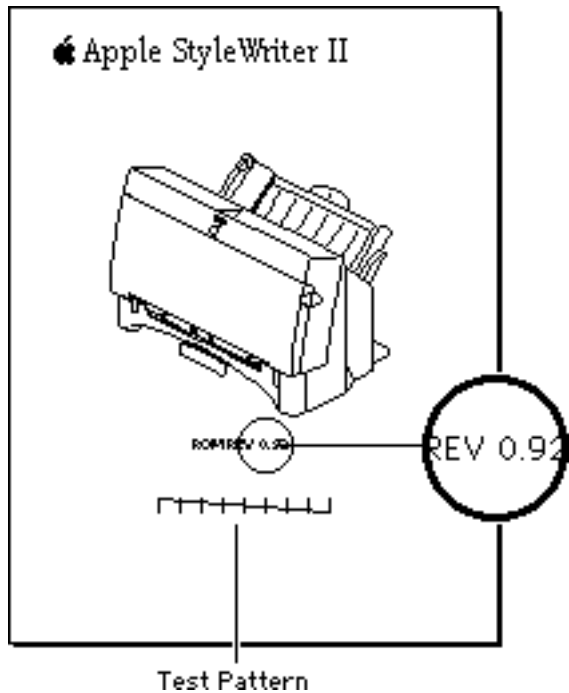

The test page shows the ROM revision and a test pattern.

Use the test pattern to determine if the ink jets are functioning properly. If lines appear broken, proceed to the “Printing” topic in the Troubleshooting chapter.





## Specifications

---

StyleWriter II





## Characteristics

**Print Methods**

Serial bubble jet ink-on-demand

**Throughput**

SHQ mode 124 cps (10 cpi)  
HQ mode 173 cps (10 cpi)  
HS mode 248 cps (10 cpi)

**Print Head**

1 by 64 nozzles

**Print Head Life**

Approximately 500 pages (normal mode)

**Input Buffer**

9K





# Graphics

## **Resolution**

360 dpi (at best mode)





## Paper Handling

### **Paper**

Size: LTR, LGL, A4

Weight: 16–24 lb.

Capacity: 100 sheets (A4, LTR)

### **Envelopes**

Size: Commercial number 10 size only (4.1 in. by 9.5 in)

Capacity: 10 envelopes

### **Transparencies**

Coated transparencies, or most inkjet transparencies





## Ink Cartridges

<b>Type</b>	Ink cartridge
<b>Ink Color</b>	Black
<b>Ink Amount</b>	Approximately 28 g (per cartridge)
<b>Life</b>	Approximately 500 pages





## Environmental

**Acoustic Noise Level**

Approximately 40 dB (reference level)

**Temperature**

41–95° F (5–35° C)

**Humidity**

10–90% (no condensation)





## Electrical

### **Power Source**

U.S./Canada: 120 VAC, 60 Hz, 0.36 A

U.K./Australia: 240 VAC, 50 Hz, 24 W

Europe: 220 VAC, 50 Hz, 24 W

### **Power Consumption**

48 W maximum





## Physical

### **Dimensions**

Height: 6.8 in. (173 mm)

Width: 13.7 in. (347 mm)

Depth: 7.6 in. (193.5 mm)

### **Weight**

Approximately 6 lb. (3 kg)





# Troubleshooting

---

## StyleWriter II





## General

The Symptom Charts included in this chapter will help you diagnose specific symptoms related to your product. Because cures are listed on the charts in the order of most likely solution, try the first cure first. Verify whether or not the product continues to exhibit the symptom. If the symptom persists, try the next cure. (Note: If you have replaced a module, reinstall the original module before you proceed to the next cure.)

If you are not sure what the problem is, or if the Symptom Charts do not resolve the problem, refer to the Flowchart for the product family.

For additional assistance, contact Apple Technical Support.





# Symptom Charts

## Preliminary Checks

Computer cannot find printer

- 1 Verify that StyleWriter II driver is installed.
- 2 Verify that Chooser and Control Panel settings are correct.
- 3 Verify that serial cable is connected.
- 4 Replace serial cable.

No lights or movement

- 1 Verify that printer is turned on and plugged into wall socket.
- 2 Replace fuse.

Print quality problems

- 1 Verify that paper is correct weight.
- 2 Purge ink cartridge.
- 3 Replace ink cartridge.
- 4 Replace printer.





### Mechanical problems

- 1 Verify that paper is correct weight.
- 2 Clear paper jam.
- 3 Verify that cut sheet feeder aligns with printer.
- 4 Replace printer.





## Status Light

No status lights

- 1 Replace fuse.
- 2 Verify that operation cable is securely connected to logic board.
- 3 Replace printer.

Error light on

- 1 Printer is out of paper; add paper.
- 2 Check for paper jam; remove jam and then press power switch.
- 3 Check for carriage jam.
- 4 Replace printer.





## Printing

### No printing

- 1 Verify that interface cable between printer and computer is tightly connected.
- 2 Make sure printer is selected in Chooser.
- 3 Purge ink cartridge.
- 4 Replace ink cartridge.
- 5 Verify that right-margin sensor is seated correctly.
- 6 Replace printer.

### Garbled printing

- 1 Verify that interface cable between printer and computer is tightly connected.
- 2 Purge ink cartridge.
- 3 Replace ink cartridge.
- 4 Replace printer.





## Overprinting

- 1 Verify that program being used is set for correct line spacing and line length.
- 2 Verify that correct printer driver is installed.
- 3 Replace printer.

## Image too light or too dark

- 1 Purge ink cartridge.
- 2 Use 16–24 lb. cotton bond paper.
- 3 Verify that forms thickness lever is set correctly (up for standard paper and down for envelopes, transparencies, labels, and heavy paper).
- 4 Replace ink cartridge.

## White lines in printing

- 1 Purge ink cartridge.
- 2 Replace ink cartridge.
- 3 Replace printer.





Page prints off center; images are out of place	1	Use 16–24 lb. cotton bond paper.
	2	Verify that sheet feeder holds no more than 50 sheets.
	3	Verify that paper is inserted properly.
	4	Verify that margins in document and paper size in Page Setup are set correctly.
	5	Replace printer.
Ink appears on back of paper	1	Clean platen with soft, dry cloth.
	2	Clean platen rollers.
	3	Replace printer.
Image wavy, splotchy, or distorted	1	Purge ink cartridge.
	2	Replace ink cartridge.
	3	Replace printer.





## Carrier Movement

Erratic carrier motion

Replace printer.

Power light is on; carrier does not move

- 1 Make sure carrier area is clear of obstructions.
- 2 Replace printer.

Printer does not perform self-test; ready light is on

Replace printer.

Carrier grinds, hums loudly, or locks

- 1 Verify that right-margin sensor is seated correctly.
- 2 Replace printer.





## Paper Feed

No paper feed

- 1 Verify that cut sheet feeder aligns with printer.
- 2 Release paper pressure plate on cut sheet feeder.
- 3 Make sure paper path is clear of obstructions.
- 4 Replace printer.

Grinding during paper feed

- 1 Make sure paper path is clear of obstructions.
- 2 Verify that forms thickness lever is set correctly (up for standard paper and down for envelopes, transparencies, labels, and heavy paper).
- 3 Verify that cut sheet feeder aligns with printer.
- 4 Replace printer.





Paper feed difficulties: binding, tearing

- 1 Verify that forms thickness lever is set correctly (up for standard paper and down for envelopes, transparencies, labels, and heavy paper).
- 2 Make sure paper path is clear of obstructions.
- 3 Verify that paper is inserted properly.
- 4 Use 16-24 lb. cotton bond paper.
- 5 Verify that cut sheet feeder aligns with printer.
- 6 Replace printer.

Envelope feed problems

- 1 When printing envelopes: (a) adjust paper thickness lever, (b) do not run cut sheets and envelopes in same print job, and (c) reset paper thickness lever when finished printing envelopes.
- 2 Replace printer.





## Miscellaneous

Operations panel  
buttons don't work

- 1 Verify that operations panel cable is securely connected to logic board and operations panel.
- 2 Replace printer.

Software-specific  
problem

- 1 Verify that software is known-good.
- 2 Verify that software is compatible with TrueType fonts.  
(Check your software application manual.)





Take Apart  

---

StyleWriter II



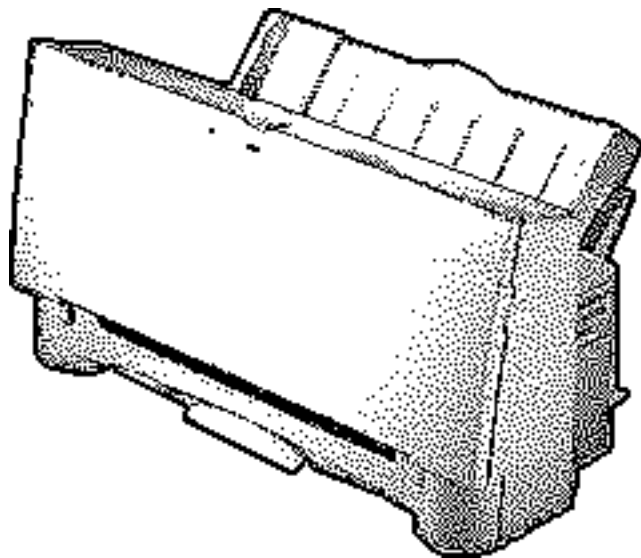

## Covers

No preliminary steps are required before you begin this procedure.

Review the ESD precautions in Bulletins/Safety.

**Caution:** Do not use excessive force to release a latch or tab.

**Note:** This procedure covers the removal of all the covers on the printer.





## Front Access Cover

- 1 **Note:** The front access cover is held in place by two arms that function as hinges. Plastic tabs at the end of the arms fit into knobs on the inside of the upper case.
- 2 Open the front access cover.
- 3 Press the end of each arm inward and free the arm tabs from the upper case.
- 4 Lift off the front access cover.

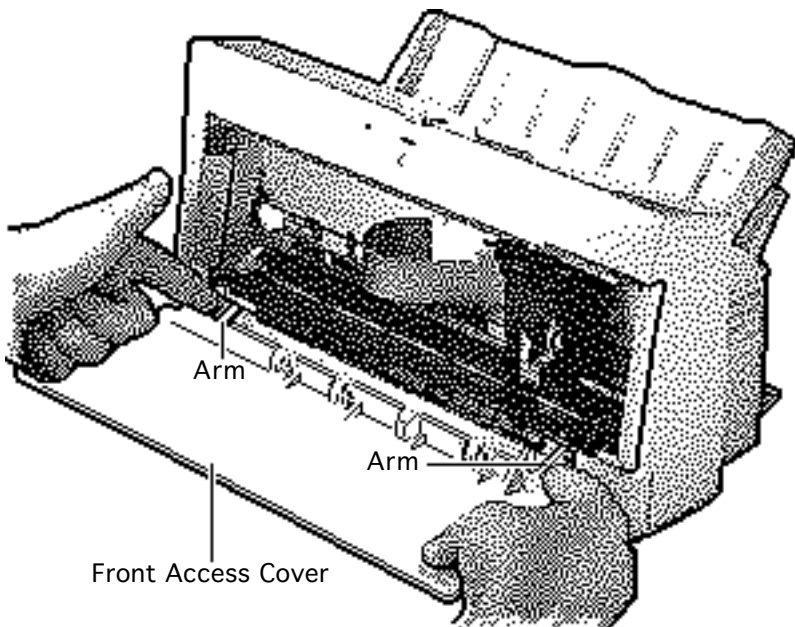



## Upper Case

- 1 Release the right side latch and lift the upper case a short distance. Repeat for the left side latch and remove the case.

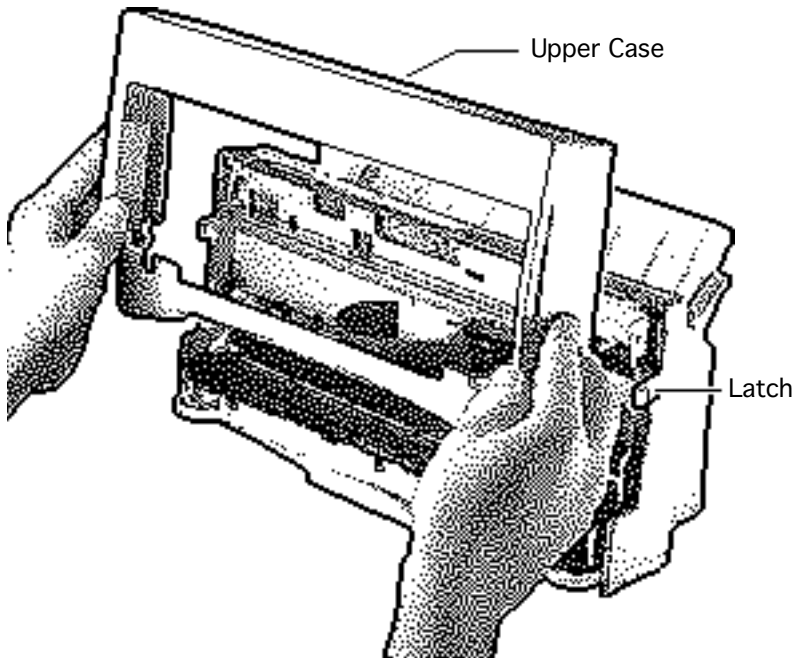



## Output Tray Assembly

- 1 Pull out the tray until the two tabs rest against the stops. Press down and remove the tray.

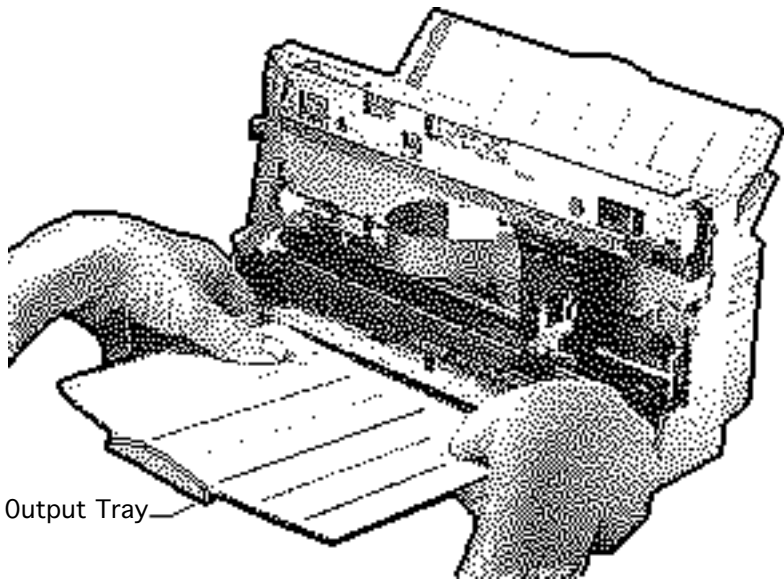



## Rear Cover

- 1 Press out the two latches on the bottom of the printer and press up on the rear cover.
- 2 Release the two latches on the top of the printer.
- 3 Lift up and remove the rear cover.

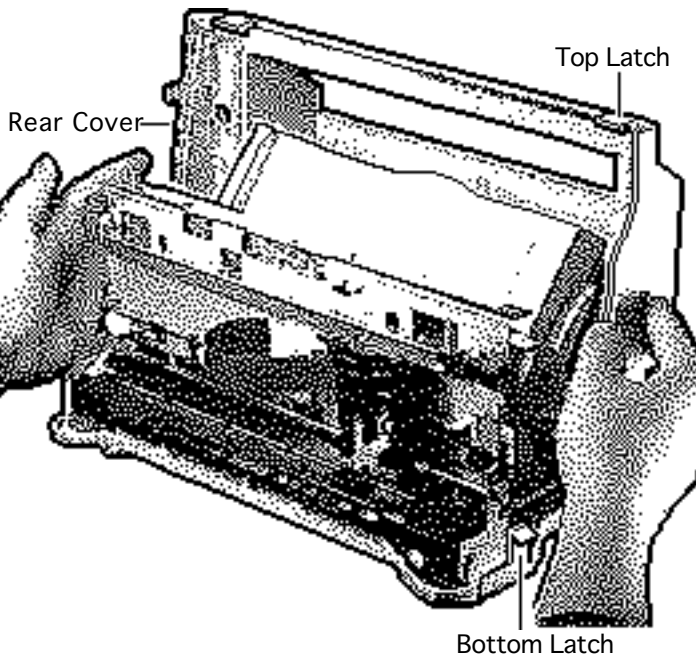

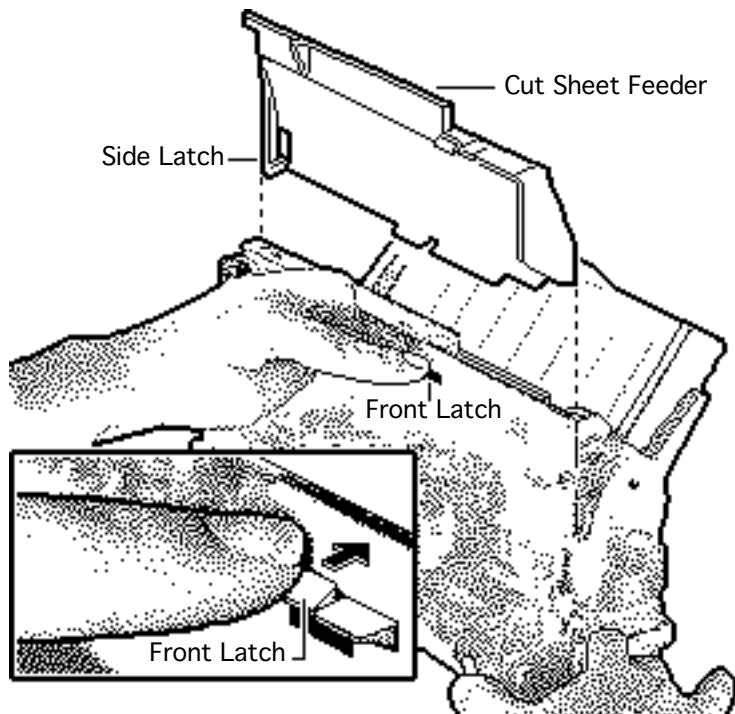

## Cut Sheet Feeder Cover

- 1 Press in the front latch and release the side latch.
- 2 Pull back and remove the cover.





## Paper Support

- 1 Pull out the paper support until it rests against the stops.
- 2 Push the support forward and disconnect the latches.
- 3 Slide out the paper support.

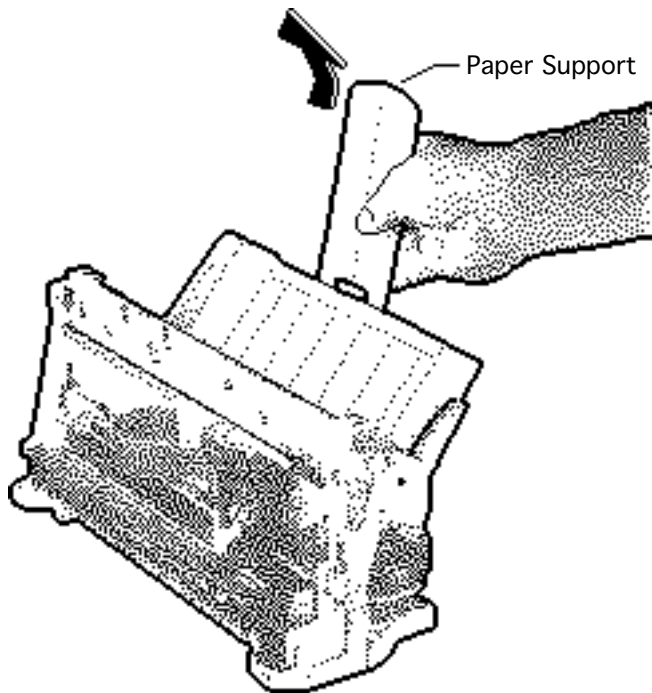



## Bottom Cover

- 1 Using a screwdriver, push out the two front latches.
- 2 Pull up and remove the bottom cover.

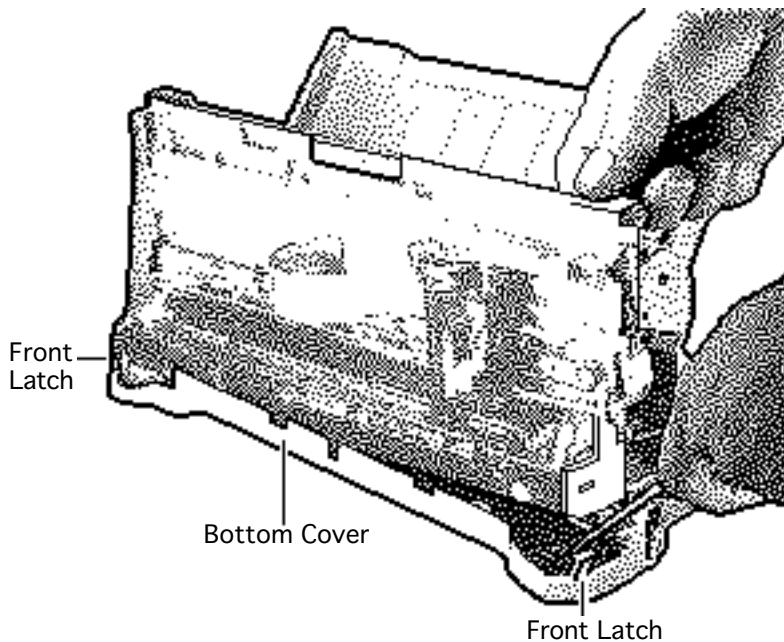

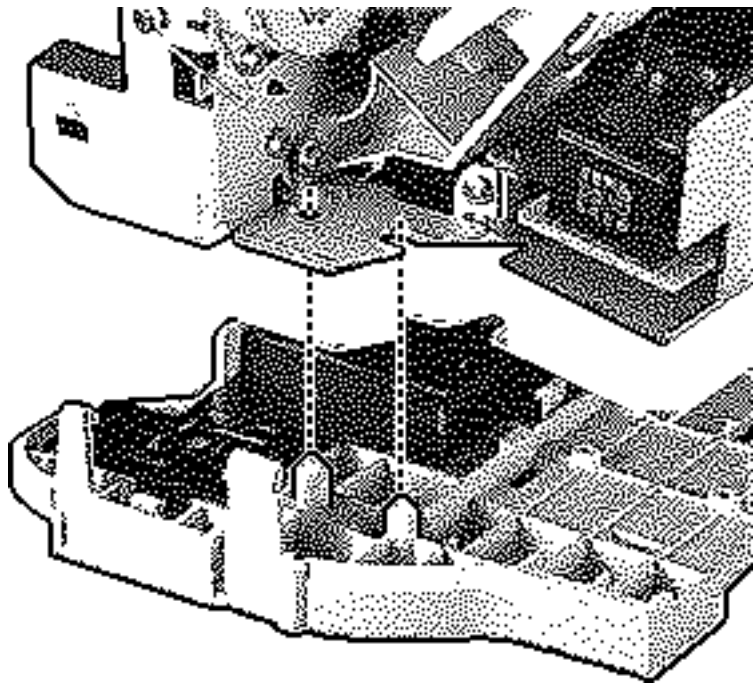

**Replacement Note:** Make sure the bottom cover circular tabs fit into the proper position in the printer frame.



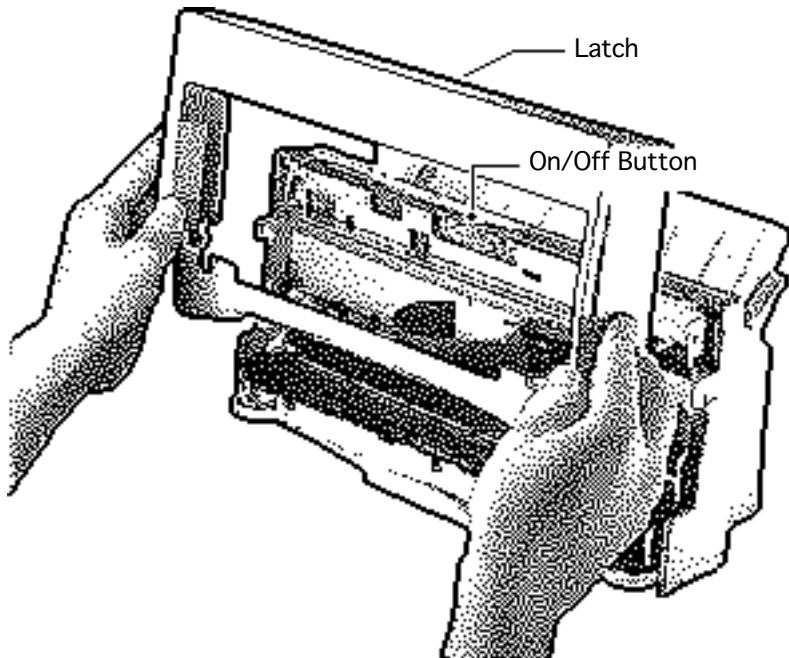

**Replacement Note:** Make sure the latch on the upper case engages the on/off button on the logic board.





## Cut Sheet Feeder

Before you begin, remove covers.

Review the ESD precautions in Bulletins/Safety.

**Caution:** Do not get the ink on your hands or clothes. Although the ink is water soluble, it contains dyes that will stain.

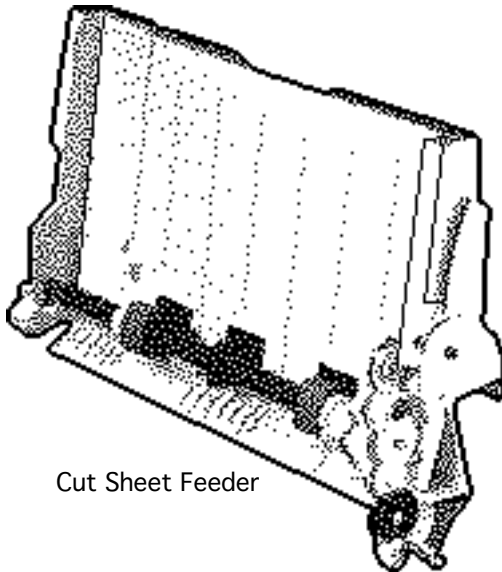

Cut Sheet Feeder



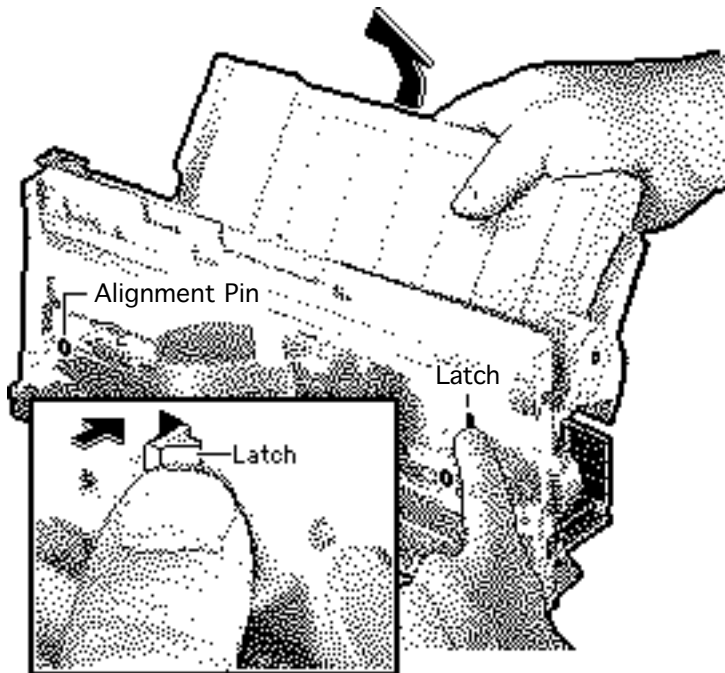

- 1 Using a Phillips screwdriver, remove the two screws that secure the cut sheet feeder to the printer.
- 2 Press in the latch and remove the cut sheet feeder.

**Replacement Note:** Make sure the alignment pins on the cut sheet feeder are aligned with the printer frame.





## Roller and Spring

Before you begin, remove front cover.

Review the ESD precautions in Bulletins/Safety.

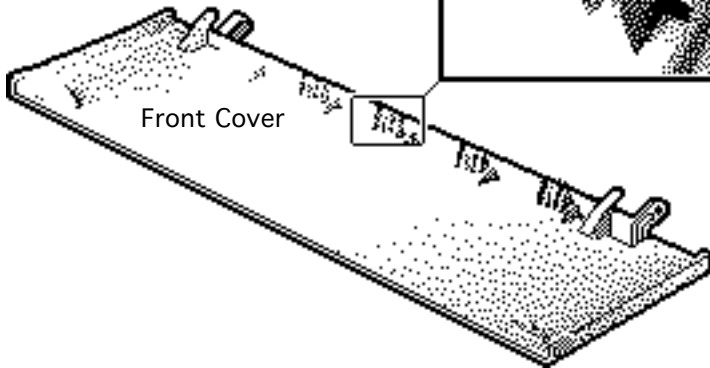
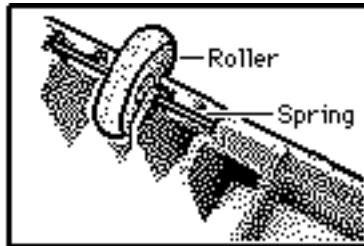



- 1 Push the roller forward slightly.
- 2 Carefully lift up and remove the roller and spring.

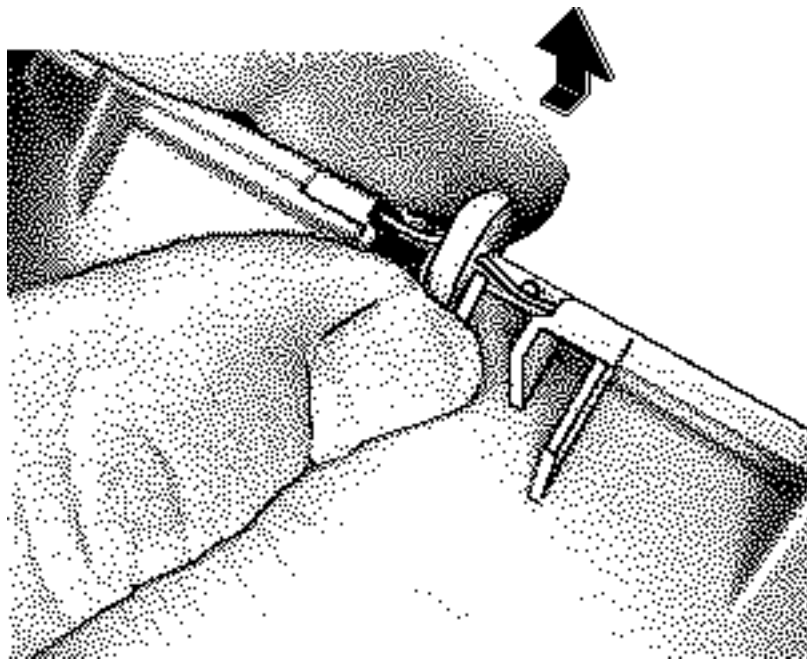



## Cut Sheet Feeder Roller

Before you begin, remove the following:

- Covers
- Cut sheet feeder

Review the ESD precautions in Bulletins/Safety.

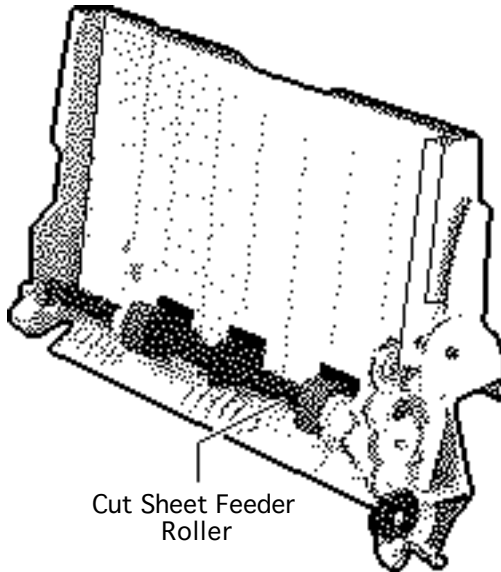

Cut Sheet Feeder Roller



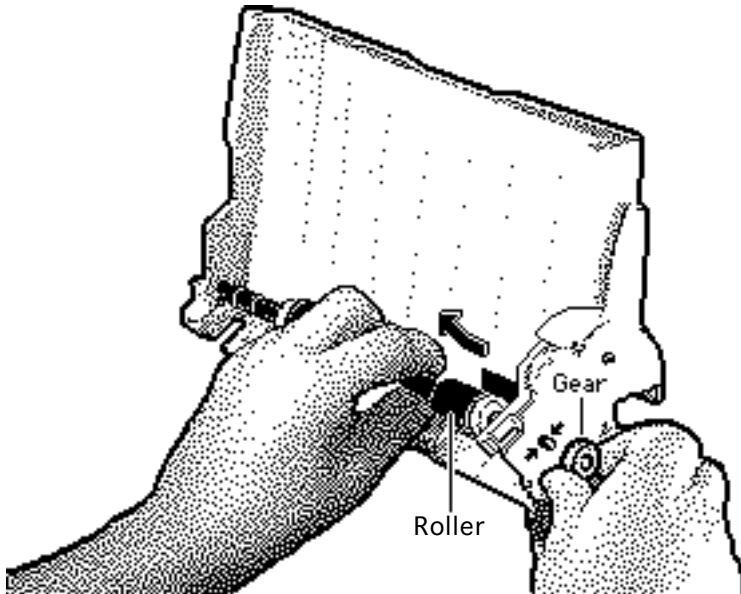

**Caution:** When the roller is removed, the feeder gear is loose. Remove the roller slowly so that the gear will not fly off.

- 1 Press in the two latches on the cut sheet feeder roller and push out the roller.
- 2 Remove the gear.
- 3 Lift up on one end of the roller and remove the other end from the mounting hole.



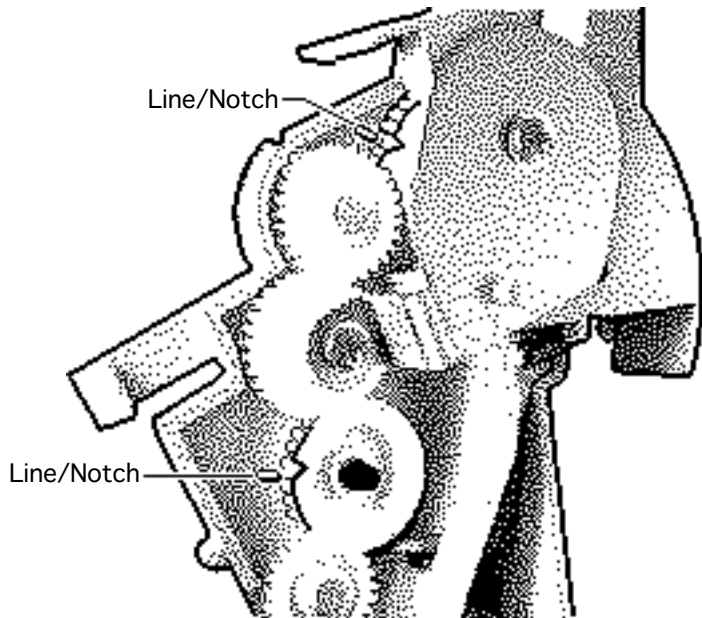

**Replacement Note:** Align the notch on the upper gear with the upper line on the cut sheet feeder. Align the notch on the lower gear with the lower line on the cut sheet feeder.





## Carriage Assembly

Before you begin, remove the following:

- Covers
- Cut sheet feeder

Review the ESD precautions in Bulletins/Safety.

**Caution:** To prevent the print nozzles from clogging, do not touch or wipe them.

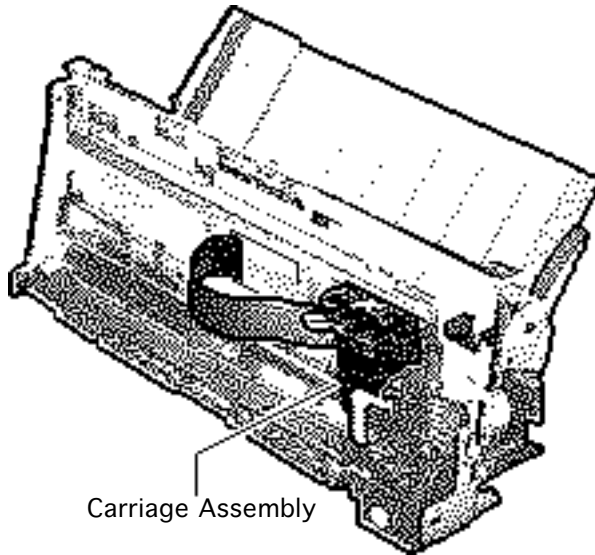

Carriage Assembly





- 1 Disconnect connector CNH from the logic board.

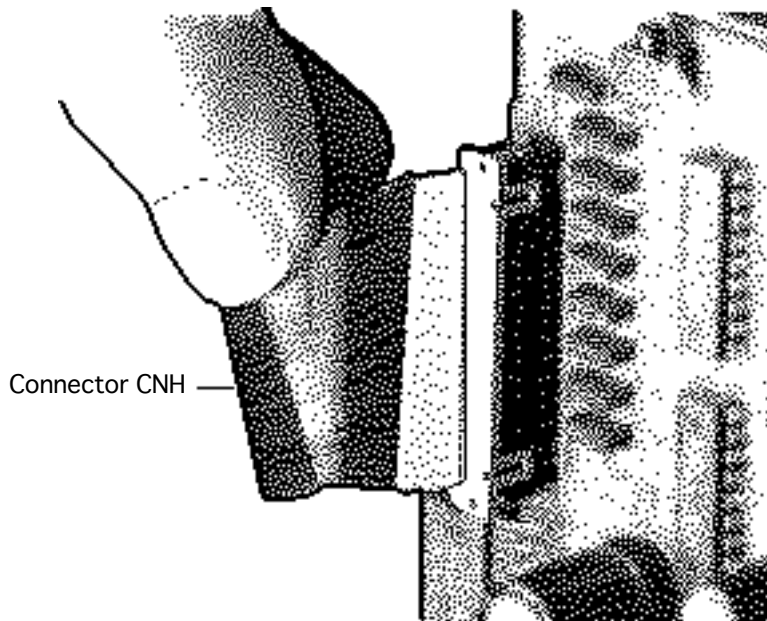



- 2 Remove the plastic ribbon cable and cable holder.

**Replacement Note:** Make sure the ribbon cable holes are mounted on the two tabs on the inside of the ribbon cable holder.

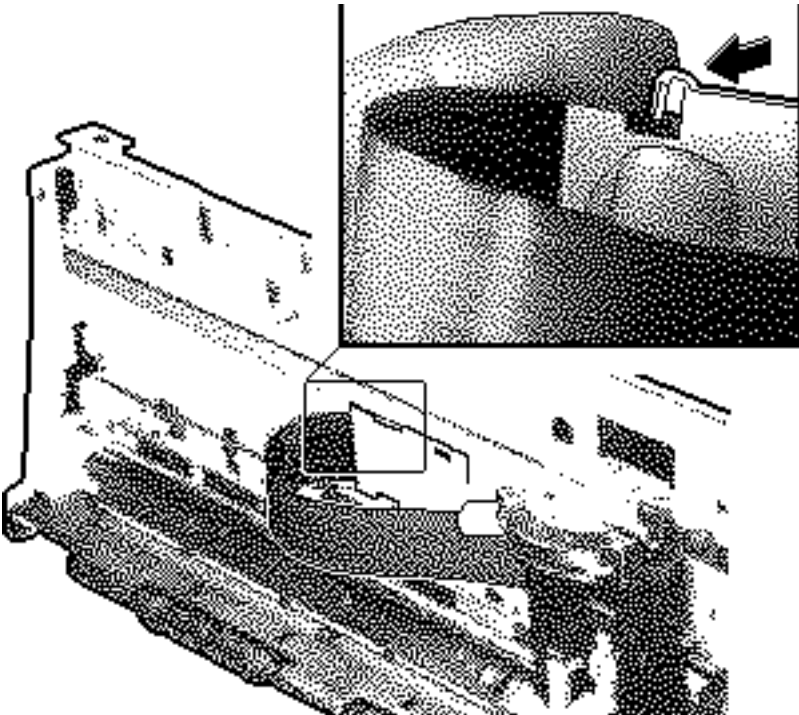



- 3 Press in the two latches.
- 4 Push up and remove the carriage release clip.

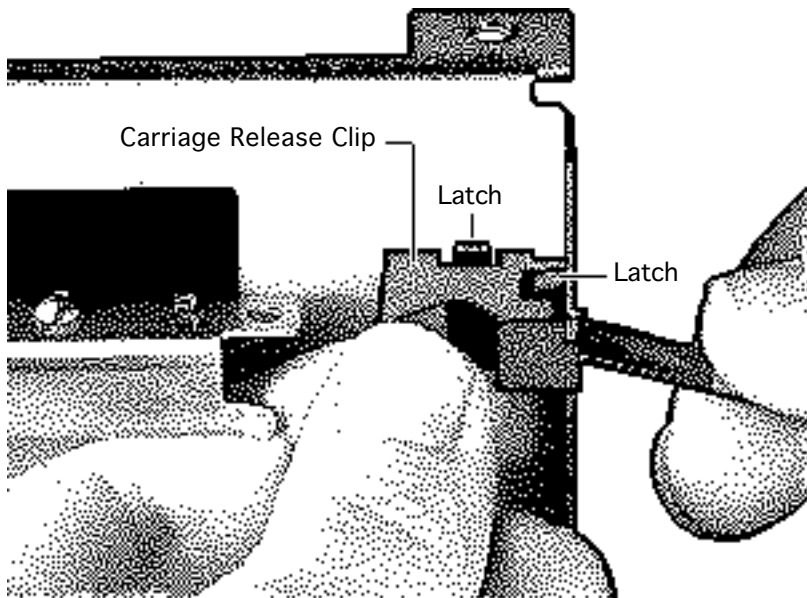



- 5 Carefully remove the shaft clips from each side of the carriage assembly.

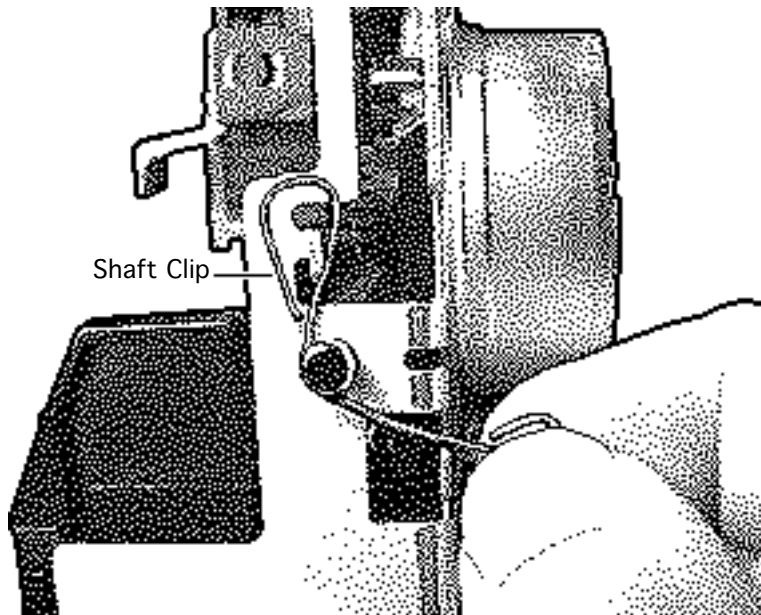

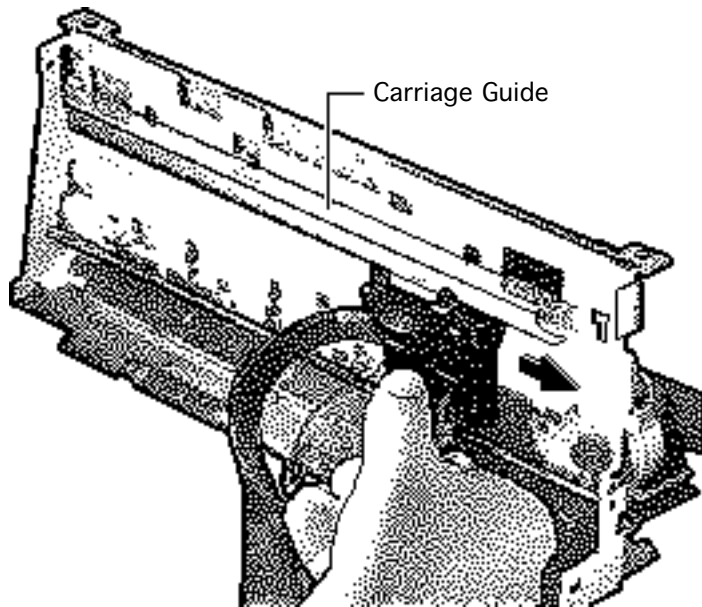

- 6 Move the carriage to the far right and disconnect the carriage from the carriage guide.

**Caution:** Do not remove or loosen the two screws on top of the carriage guide. Loosening or removing these screws will cause the carriage to go out of alignment.





- 7 Using a flat-blade screwdriver, carefully press in the idler roller and disconnect the carriage belt.

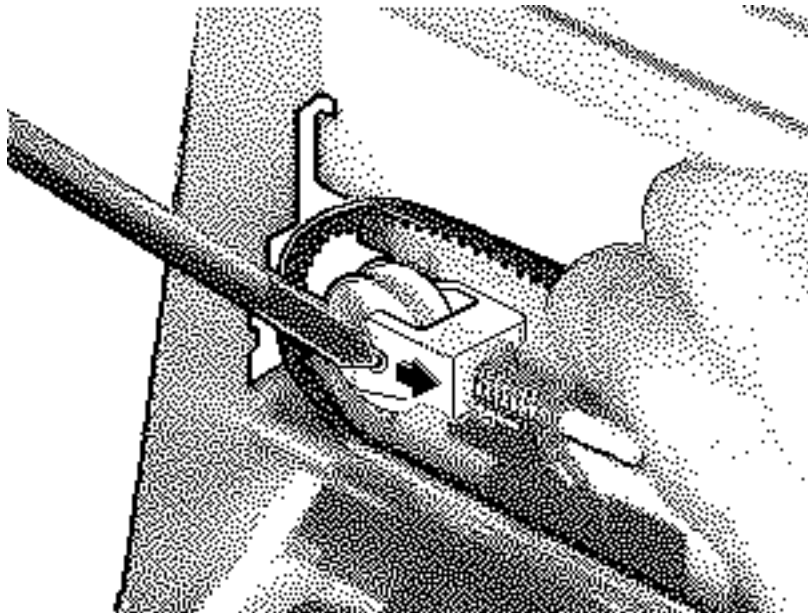

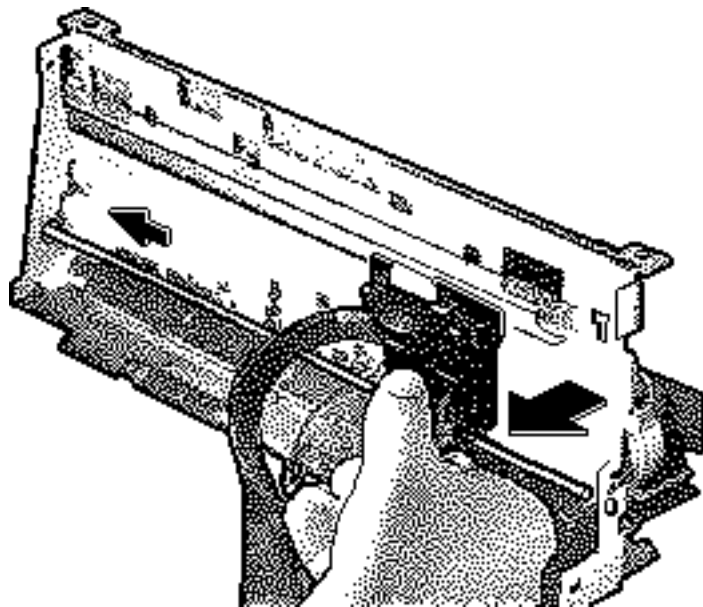

- 8 Hold the carriage assembly and push back the carriage shaft.
- 9 Slide out the carriage shaft.





## Carriage Motor

Before you begin, remove the following:

- Covers
- Cut sheet feeder

Review the ESD precautions in Bulletins/Safety.

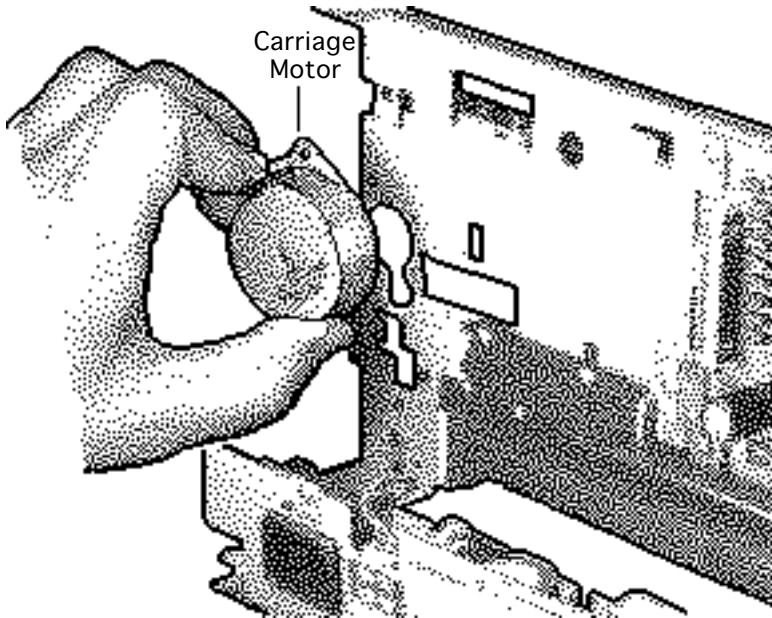



- 1 Disconnect connectors CNH and CNCR from the main board.

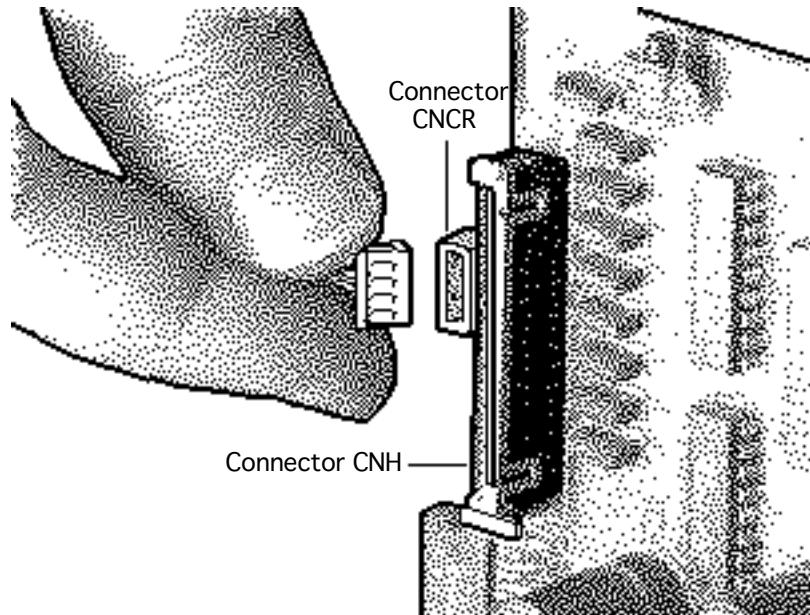



- 2 Using a flat-blade screwdriver, press in the idler roller and disconnect the carriage belt.

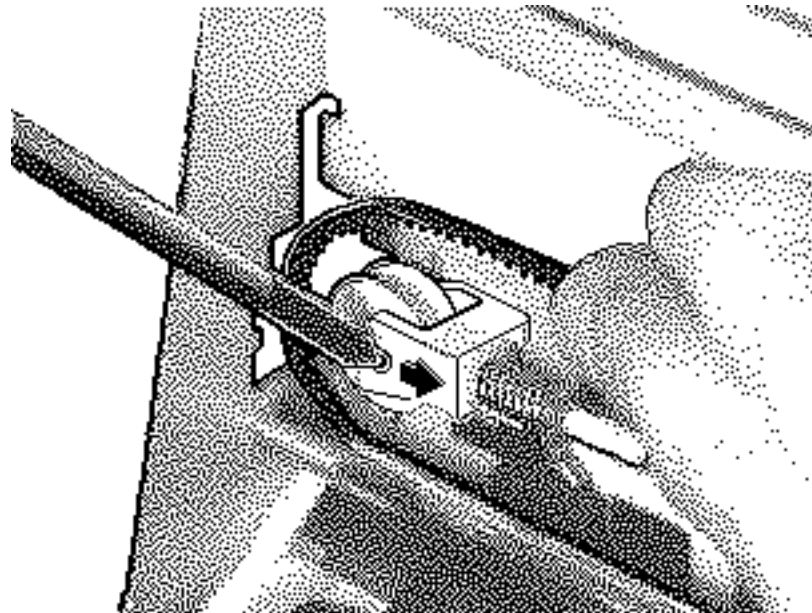

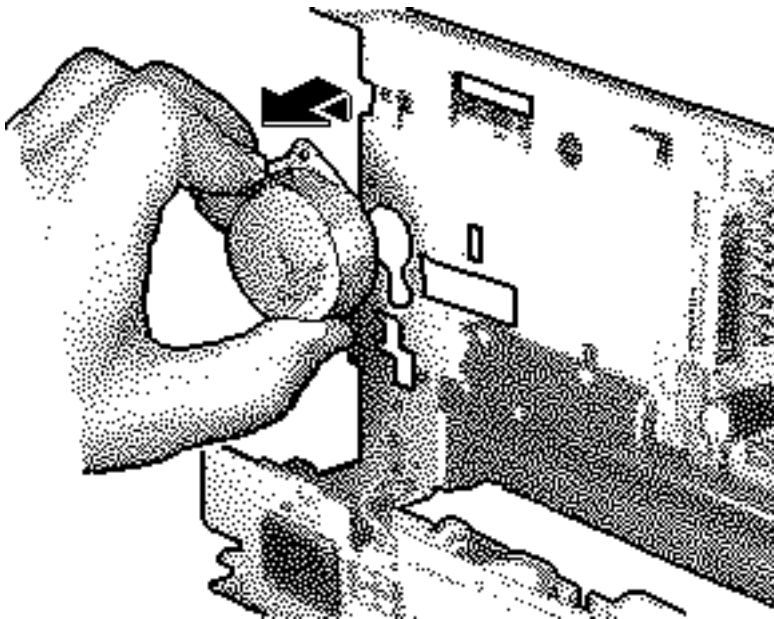

- 3 Using a Phillips screwdriver, remove the two mounting screws.
- 4 Lift up and pull out the carriage motor.



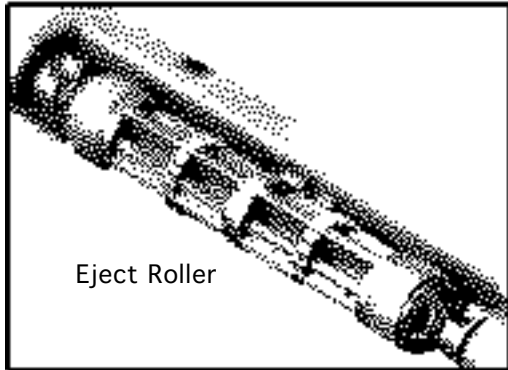
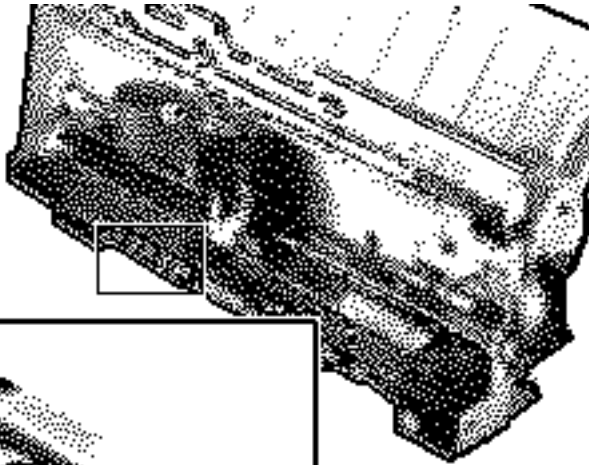

## Eject Roller

Before you begin, remove covers.

Review the ESD precautions in Bulletins/Safety.





- 1 Grasp one end of the roller, press it firmly to the side, and snap the roller out of the mounting holes.

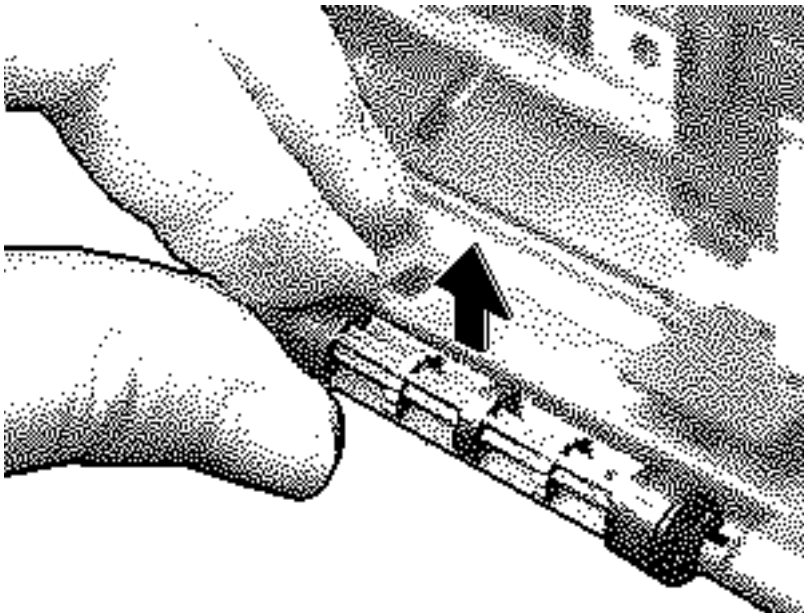

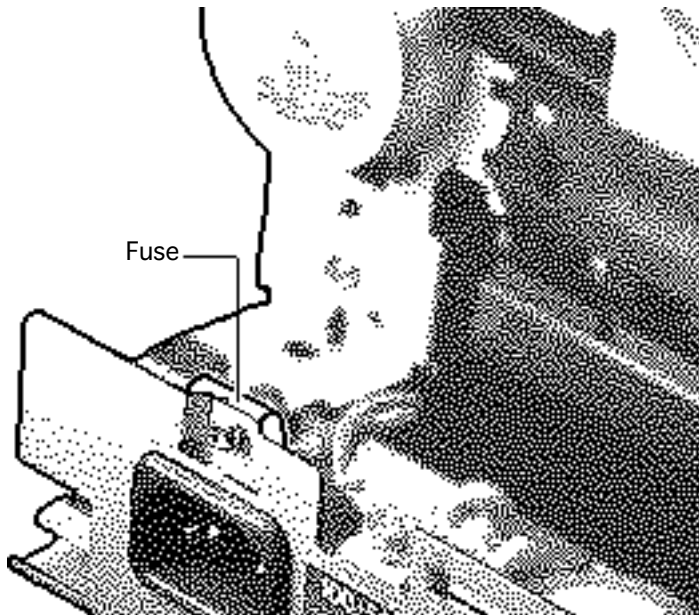

## Fuse

Before you begin, remove the following:

- Covers
- Cut sheet feeder

Review the ESD precautions in Bulletins/Safety.





- 1 Remove the fuse cover and replace the fuse.

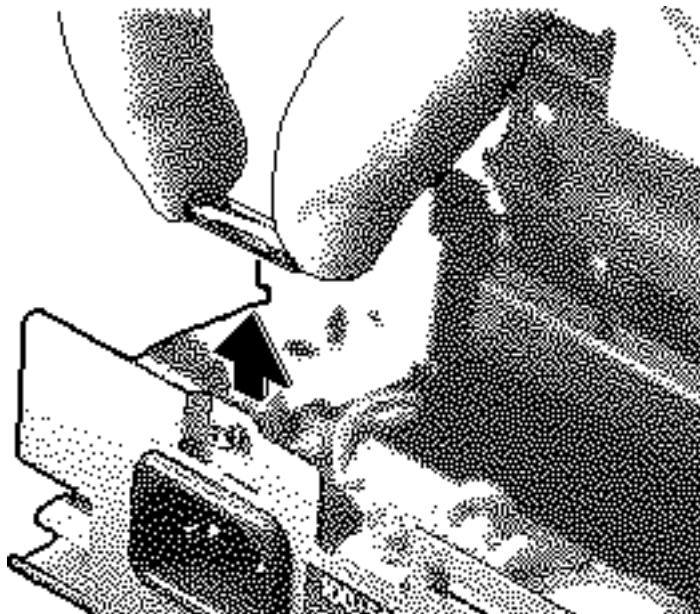



Exploded View

---

StyleWriter II



